

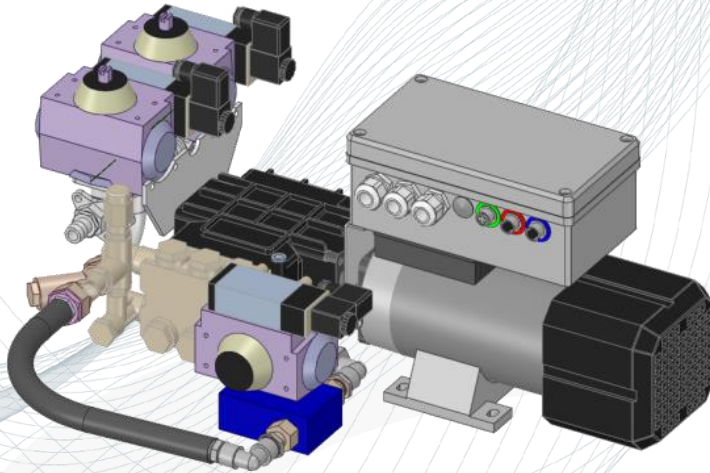

ELECTRONIC FOAM PROPORTIONING SYSTEM DOSIFOR™-5NPI



Nominal Pressure: 40 bar
 Pump: 0.3 - 5 l/min
 Dosage: 0.1 - 6%
 Water Flow (DN40): 40 - 750 l/min
 Current consumption: 24 V - 40 A
 Dimensions: 630 x 410 x 250 mm
 Weight: 27 Kg

The **DOSIFOR™ - 5NPI** is an electronic proportioning system -controlled by a microprocessor- specially designed for the accurate injection of foam concentrates or other additives into a water line with an nominal flow rate of 5 lpm at a pressure of 40 bar. Its application is the proportioning of all kind of foamconcentrates, including Newtonian foam concentrate with low viscosity or anti-alcohol foam ones with pseudoplastic behaviour.

Advantages of the system

Automatic System:

- Cleaning
- Priming

Functional system:

- No water pressure drop.
- Compatible with class A type foam concentrates.
- Ease of installation.
- Ease of implementation.
- Easy maintenance.
- Reduced dimensions.

Efficient System:

- Actual water and foam concentrate flow rate measurement.
- Precise injection of foam concentrates.
- Injection in high pressure system.
- Extinguishing efficiency.
- Shorter intervention time.
- Greater autonomy.

Water Flow Sensor:

- EM-40
- Electromagnetic
- Between flanges
- DN-40
- 40 - 750 lpm
- 15 bar



*Other options available

ADVANTAGES OF THE SCREEN

Unit Box	Visualization	Functions	Features
Can be used with gloves	Actual water and foam flow	Automatic or manual mode	Connection Bus CAN
Protection IP65	Actual water and foam pressure (optional)	Dosage ratio adjustment	Color touch screen 7"
Easy use	Tank level and capacity (optional)	Choice of foam tank	Connection with vehicle (optional)
Sunlight readable	Foam pump working speed	Cleaning and priming the pump	Totalizers



Functional Diagram

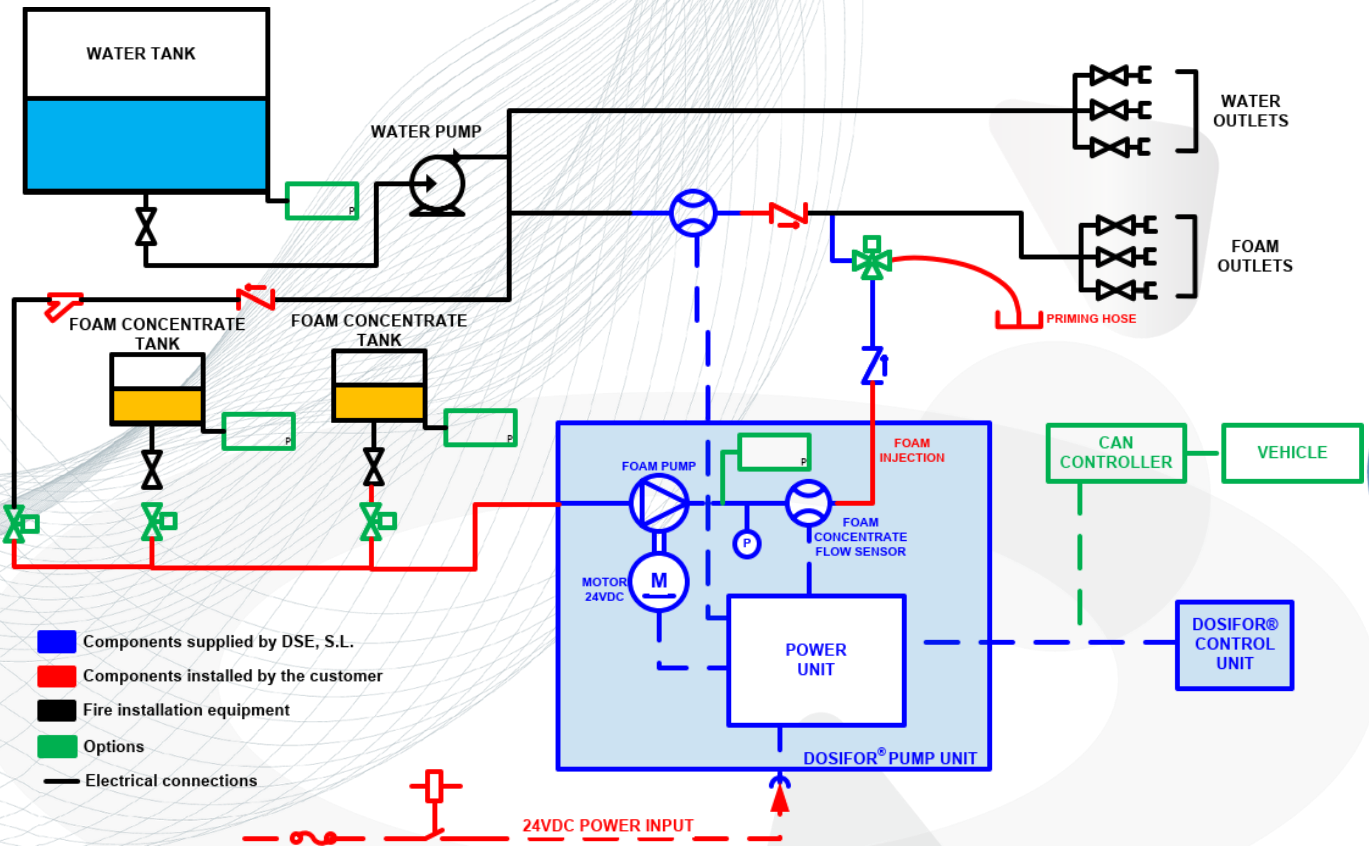

The **DOSIFOR™ - 5NPI** measures the flow rates of water and foam concentrate modifying the speed of the foam pump to maintain the specified proportioning rate, independently of the fluctuations of water flow rate and pressure. In addition to the automatic control mode, the system has a manual mode that allows the manual adjustment of the speed of the pump (for priming, cleaning, calibration...).

Control Unit



The **DOSIFOR™ - 5NPI** control unit consists of a high luminance, sunlight readable 7" color touch screen display that is easy to use filled with useful information for the user. This unit displays actual water and foam concentrate flow rates, as well as totalizers and foam concentrate pump operating information.

Thanks to the touch panel and its ease of use, it is very easy to adjust the dosage ratio, select the operating mode (automatic or manual) and the foam concentrate tank, and perform basic operations such as priming or flushing the foam concentrate pump.

A very important advantage of this control unit is its great flexibility, as it can optionally display the water and foam concentrate pressure, as well as the tank levels of both the water and foam concentrate tanks. In addition, if connected to the vehicle's CAN bus J1939, it can also display useful information on engine performance, such as oil pressure, coolant temperature, battery voltage and fuel tank level, as well as PTO running time, this function is optional and must be requested by the customer.